

ELISA™

Aquahub™

COMPATIBLE WITH:

DC001CH / DC001BB / DC001MB
DC002CH / DC002BB / DC002MB
DC003CH / DC003BB / DC003MB
PB002CH / PB002BB / PB002MB
PB003CH / PB003BB / PB003MB

AQUAHUB UNIVERSAL CONCEDED INSTALLATION BOX - AHUB1

DIMENSIONAL DRAWINGS

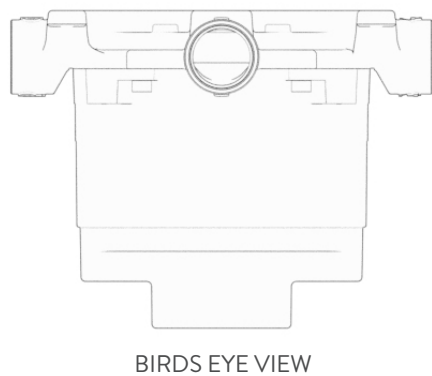
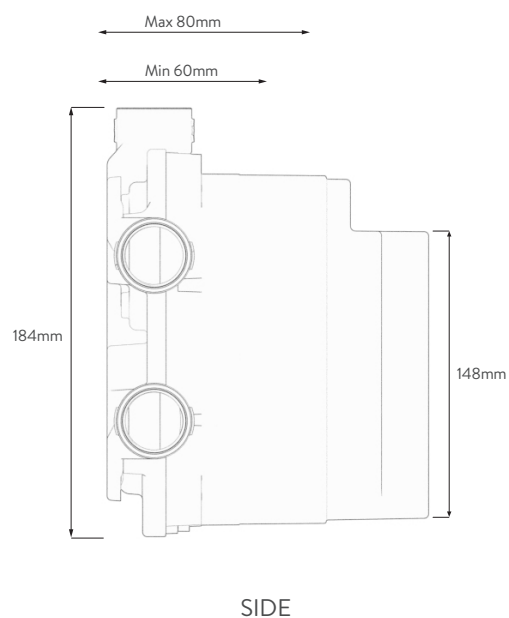
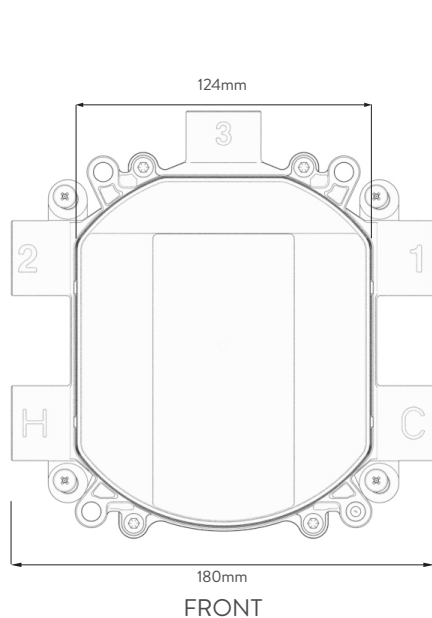



COMPATIBLE WITH:

DC001CH / DC001BB / DC001MB
 DC002CH / DC002BB / DC002MB
 DC003CH / DC003BB / DC003MB
 PB002CH / PB002BB / PB002MB
 PB003CH / PB003BB / PB003MB

AQUAHUB CONCEALED UNIVERSAL MIXER

TECHNICAL SPECIFICATIONS

Min Pressure	1 bar
Max Pressure	10 bar
Fitting connections	3/4"
Outlet connections	3/4"
Inlet supply positions	Left hot, Right cold
Features	Front and rear mounting options
	2 stage fixing for 1st and 2nd fix installations
	Slim 60mm minimum installation depth
	Reversible inlets in case plumbed incorrectly
	One box suitable for 1,2 and 3 outlets as well as push button or dial operation
	Intergrated isolation valves
	8 fixing points for flexible installation
	Theromstatically controlled
	Flow control
	Quality brass valve
Flush block testing plate	
Guarantee period	15 years (Please see guarantee Ts and Cs for more information)