

Installation instructions for positive duty pumps

Mach 120 MC0120

INDEX	Page No
Application	1
Storage	1
Typical installation	2
Pump location	2
Pipework	5
Pump connections	6

INDEX	Page No
Electrical installation	10
Commissioning	12
Maintenance	14
Trouble shooting guide	15
Technical specification	17
Noise	17

PRODUCT DESCRIPTION

Electric motor driven double sided peripheral pump, complete with an automatic control system, consisting of flow switches and electronic controls.

APPLICATION

Aqualisa Positive Duty pumps are designed for pressure boosting shower applications in vented stored hot and cold, clean fresh water systems, where under gravity, some flow is available. Inlet pressures to the pump and ambient temperatures must not exceed the values given in the technical specifications.



- This pump set must not be used for any other application without the written consent of Aqualisa Products Limited and in particular, must not be connected directly to the mains water supply.
- This appliance is not intended for use by persons (including children) with reduced physical, sensory or mental capabilities, or lack of experience and knowledge, unless they have been given supervision or instruction concerning use of the appliance by a person responsible for their safety. Children should be supervised to ensure that they do not play with the appliance.

STORAGE

If this product is not to be installed immediately on receipt, ensure that it is stored in a dry, frost and vibration free location in its original packaging.

Please leave this instruction booklet with the pump as it contains maintenance and safety information.

TYPICAL INSTALLATION

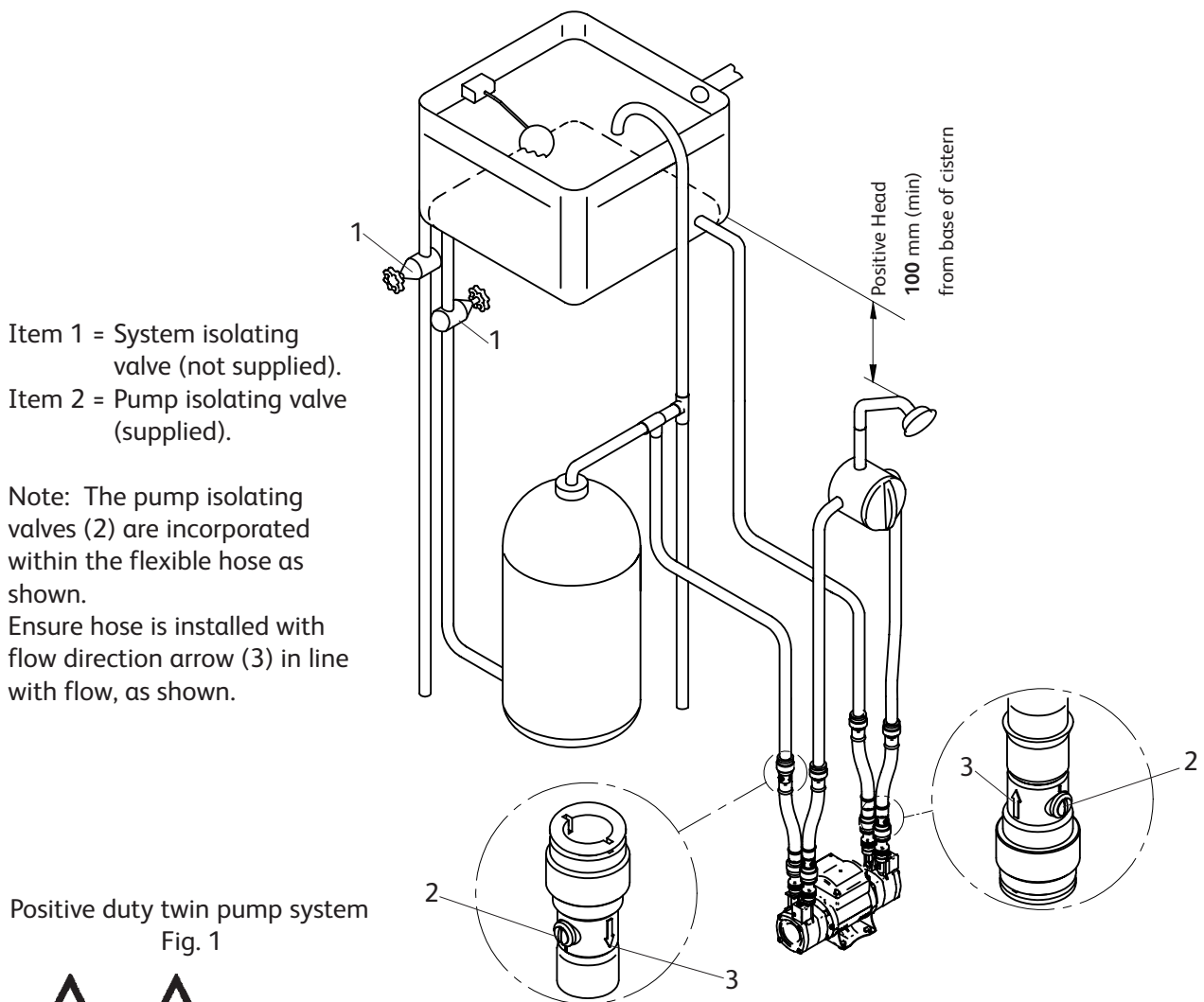

The plumbing installation must comply with the following:

The Water Supply (Water Fittings) Regulations 1999.

BS6700 and building regulations.

Be installed by a competent person.

- If in doubt consult Aqualisa customer helpline on 01959 560010.

STEP 1 PUMP LOCATION

WARNINGS:



- The pump must not be located where the static inlet pressure to the pump is greater than 13 metres (1.3 bar).
- Care should be taken to protect pump from frost, particularly when located in loft position.
- Pump location:
If possible site the pump in a location where in the unlikely event of a water leak, any spillage is contained or routed to avoid electrics or areas sensitive to water damage.
- The motor casing can become very hot under normal operating conditions, care should be taken to ensure it cannot be touched during operation.

The pump must be installed so that the following conditions are met:

Locate the pump in a dry, frost free position where it cannot be sprayed with water. It should be positioned horizontally on its antivibration mounting feet and should not be screwed down. It should be positioned as close to the water source as possible, having a minimum flooded suction head of 1 metre at all times.

Ensure the water flow is in the direction of the arrow that is marked on the pump body outlet port (vertically upwards) (see Fig. 7).

For the pump to function correctly, it must be installed in a positive head position, a gravity flow of approx. 0.8 litres per minute is required from the highest outlet to operate the built-in flow switch. This is normally achieved with a static head of 100 mm from base of the cold water storage cistern to highest position of the shower terminal fitting.

Before deciding where to position the unit, check to ensure the static inlet head of water above the pump does not exceed the values given in Figs. 2 or 3.

Typical pump locations are in an airing cupboard, or inside a vanity unit with a small purpose built dry and ventilated enclosure. The enclosure should have a minimum clearance of 80 mm (3 ") between the pump and housing on all sides. The enclosure should be secure and access should only be available by the use of tools.

The resilient antivibration mounting feet and flexible hoses which are supplied as standard, are a precaution to reduce noise transmission, however care must be taken when mounting the pump that any noise is not amplified through loose panels, pipework or other mounting medium.

The preferred pump location is at floor level next to the hot water cylinder or a level that is below the secondary tapping that feeds the pump. This will ensure the pump has access to an air free water supply which is important for trouble free operation (see Fig. 2).

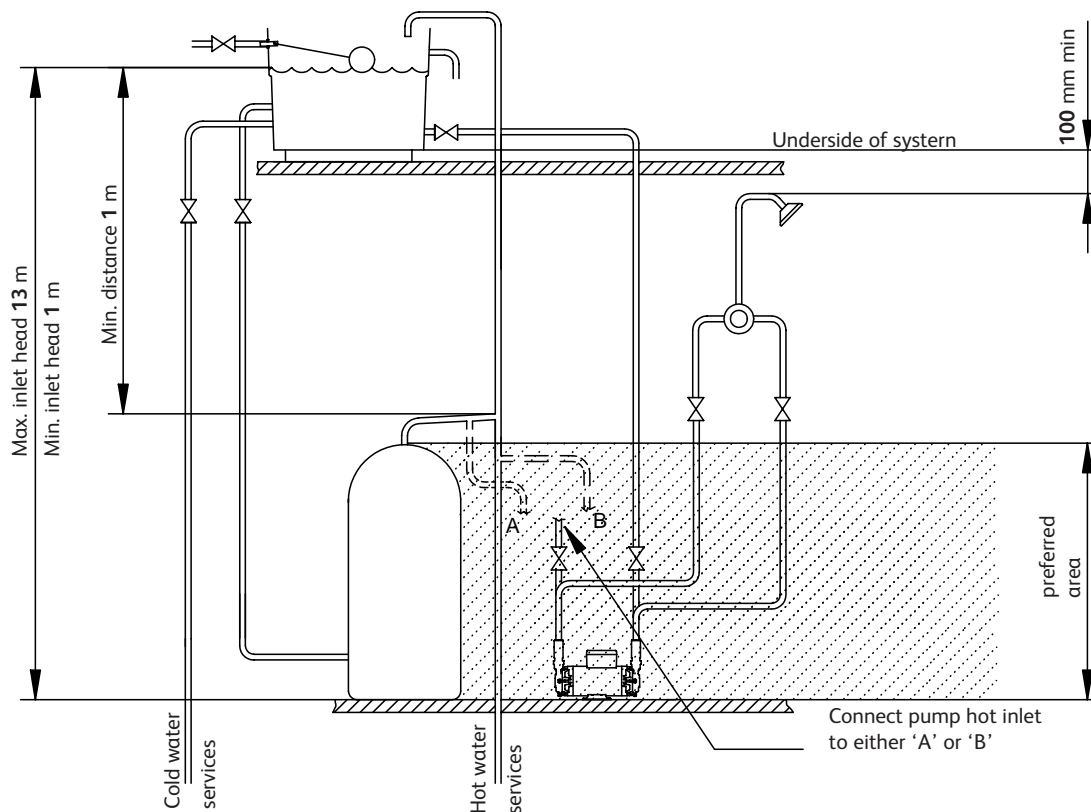

Fig. 2

Preferred pump location (shaded area). Pump at a level below draw off tapping in cylinder.

If it is not possible to locate the pump in the preferred area due to site limitations and it is necessary to position the unit in the loft, or in a position above the secondary tapping that feeds the pump, then there is an increased risk of air locks. This risk must be eliminated. The following measures are suggestions that may overcome the problem:

- 1) A "U" bend or downward loop in the supply pipe to the pump of 350 mm depth before rising to the pump should ensure the cylinder vents its air up the expansion pipe not up the pump feed (see Fig. 3).
- 2) An alternative to the above would be the installation of an automatic air vent situated at the top of a vertical pipe run, directly connected to the pump discharge. This will ensure any air collecting in the pump is automatically vented.

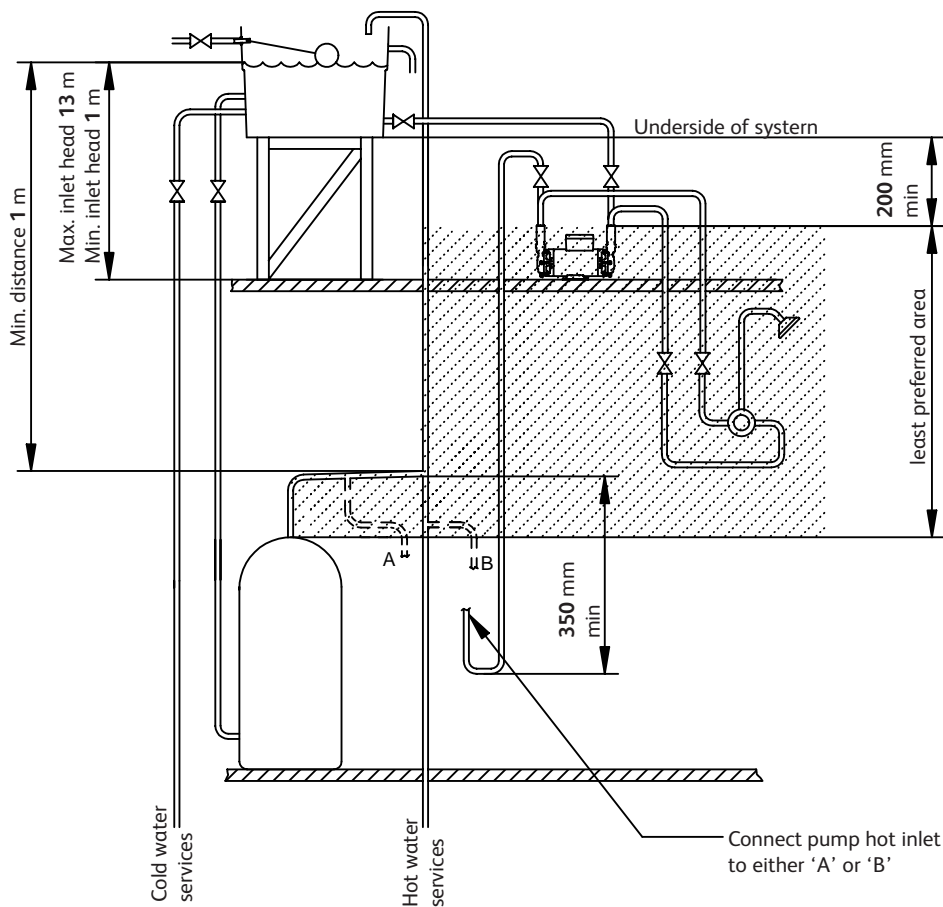

Fig. 3

Least preferred pump location (shaded area). Pump located above the hot cylinder can increase the risk of air locks.

Note: If installed in loft there must be a height of 200 mm from base of cistern to pump.

Cont....

STEP 2: PIPEWORK (General)

WARNINGS:



- Ensure pipework to and from pump is independently supported to prevent forces being transferred to inlet and outlet branches of pump.
- Do not introduce solder flux to pumps or pump parts manufactured from plastic. All solder joints should be completed and flux residues removed prior to pump connection.
- Do not allow contact with oil or cellulose based paints, paint thinners or strippers, acid based descalents or aggressive cleaning agents.
- **Do not install a non-return valve, or devices which contain non-return valves, in the suction (inlet) pipework to the pump. The pump must be free to vent to the cold water storage cistern at all times.**

It must be ensured that the water storage capacity is sufficient to meet the flow rates required by the pump and any other water using fittings and appliances, which may be operated simultaneously.

As a rule of thumb: assuming a cold water temperature of 10°C and a hot water temperature of 65°C.

- **A 6-minute shower using 10 litres/min will consume 40 litres of hot water and 20 litres of cold. This means the total quantity of water used from the cold water storage cistern will be 60 litres (40 + 20).**
- **A 10-minute shower using 15 litres/min will consume 100 litres of hot water and 50 litres of cold. This means the total quantity of water used from the cold water storage cistern will be 150 litres (100 + 50).**

The pipework feeds to the storage cistern should be of adequate size to ensure replenishment rate of cistern is sufficient to meet the needs of the pump.

Care should be taken in the design of pipework runs, to minimize the risk of air locks.

The pumps should be supplied with balanced pressure hot and cold supplies.

To prevent loss of water pressure through pipework use 22 mm pipework throughout. Any bend requirements should be achieved by hand drawing the tube or by the use of the appropriate bend fittings. All pipework should be securely clipped.

Isolating valves are incorporated in the flexible hoses that are connected to the suction and delivery pipework to enable easy isolation and access to the pump.

When pump is to be installed in areas where there is a risk of debris or scale build up within the system, it is recommended that both hot and cold inlets are fitted with inline strainers, (these are not supplied with the kit).

Pipework connections (Cold)

The pump must be supplied with a dedicated feed direct from the cold water storage cistern.

The supply must be air free and connection of the feed pipe to the cistern should be via a tank connector, positioned at a slightly lower level (25 mm minimum) than the feed pipe to the hot water cylinder.

Pipework connections (Hot)

When a hot water cylinder or storage tank is used, ensure the pipework size from the cold water storage to the hot water storage is of adequate size and a minimum of 22 mm.

The pump must be supplied with a dedicated feed direct from the hot water cylinder or hot water storage system.

The supply must be air free and connection to the cylinder can be made by one of the methods shown in Fig. 4.

When the method of connection is to be made via the expansion pipe, the cold water storage cistern should be at least 1 metre above the top of the hot water cylinder.

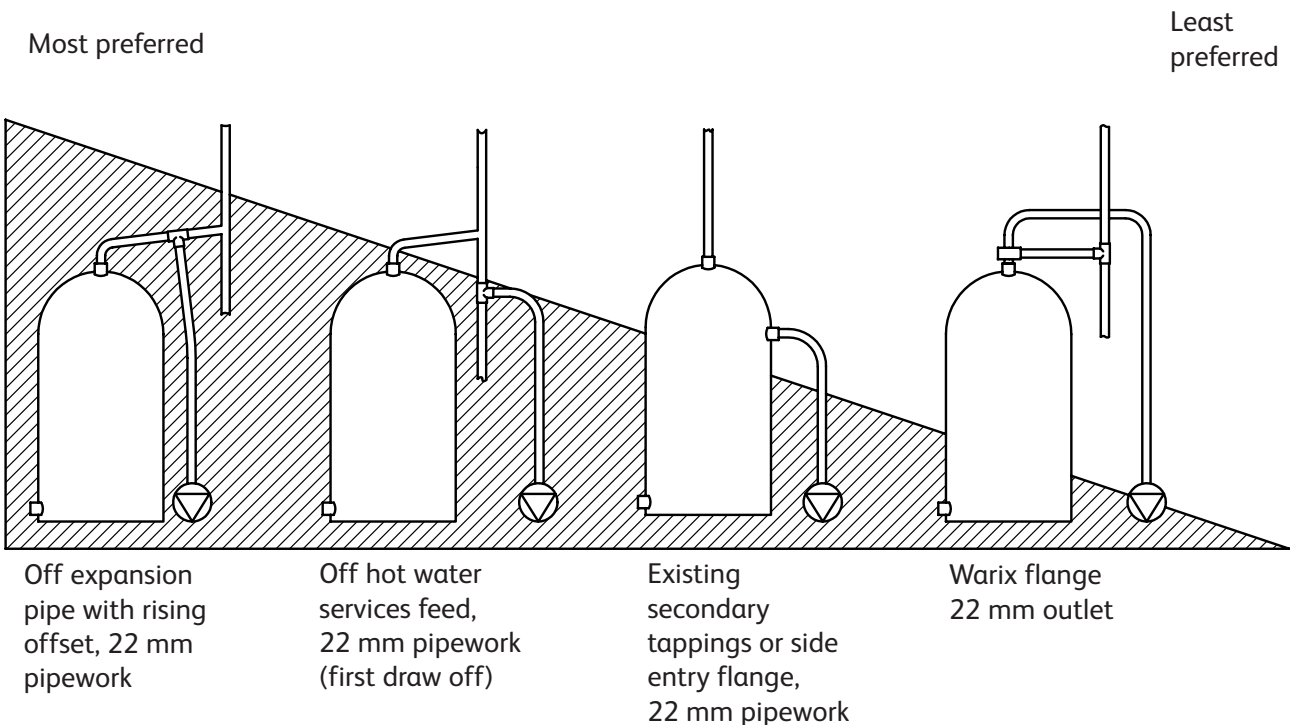

Fig. 4

Pipework connections (Connection between pump and system outlet)

This should run as far as possible in 22 mm copper tube. Pipework should only be reduced to 15 mm copper if necessary when entering the terminal fittings. By this method the maximum performance of the pump will be maintained.

STEP 3 HOSE CONNECTIONS (Release and connection of push-fit connectors)

WARNINGS:



- Do not use stainless steel, chrome or nickel plated pipe with the flexible hose push-fit plumbing connections.
- Do not introduce solder flux into the joint or surrounding area as connectors will be attacked and may fail.
All solder joints should be completed and flux residues removed before final connection to push-fit connections, on the flexible hose.
- Do not allow contact with oil or cellulose based paints, paint thinners or strippers, acid based descalents or aggressive cleaning agents.

The pump is supplied with flexible hoses for connection to inlet and outlet pipework. It is recommended that only the Aqualisa hoses supplied are used for making these connections.

Hose to pump

The pump inlet and outlet ports have factory assembled fittings which are specifically designed for connection to the push-fit Aqualisa hose. The hose should be orientated as shown in Fig. 7 and pushed firmly onto the fitting until the pipe stop resistance is felt.

Pull on the hose to check it is secure and correctly fitted.

Hose to pipework

1. The hose is fitted with plastic push-fit connectors, which must only be connected with the following:

- a) 22 mm diameter copper pipe to BS EN 1057 - R250 (half hard) - Table 3.
- b) 22 mm plastic pipe to BS 7291 part 1 and part 2 (Table 1), or part 3 (Table 1) plus internal support sleeve*.

* The internal bore of the plastic pipe must be supported against collapse with the pipe manufacturers recommended support sleeve (pipe insert).

Ensure the pipe is free from all score marks and deformities in the area of the insertion depth (see Fig. 5) and cut the pipe square removing all burrs and sharp edges to prevent damage to the sealing 'O'-ring.

2. Prior to inserting pipe into fitting mark the insertion depth on the wall of the pipe with a soft pencil at a distance of 35 mm from the end to be inserted.

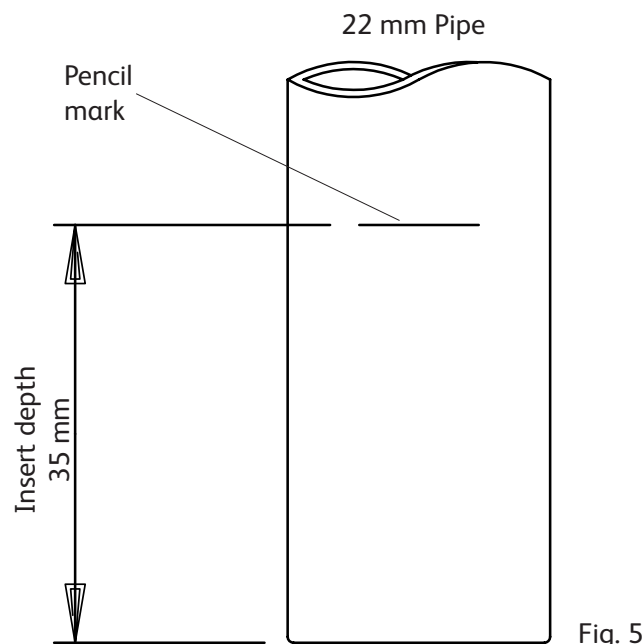

Fig. 5

Cont....

3. Check in the mouth of the fitting that the 'O'-ring, grab ring and collet are in position.

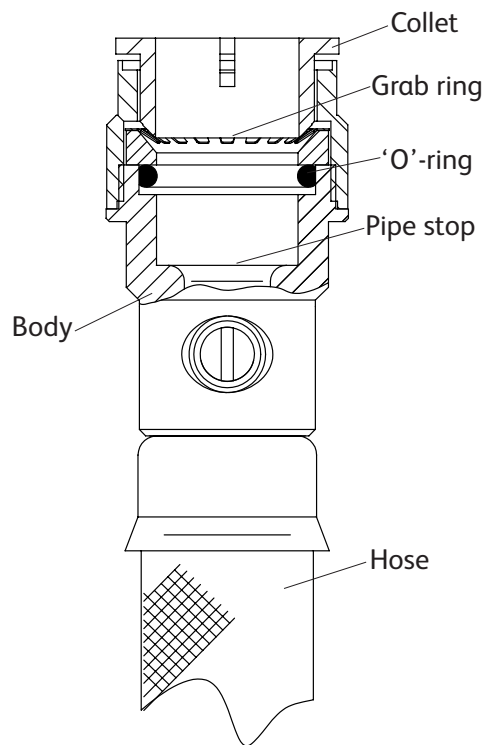

Fig. 6

4. Push pipe firmly into fitting, until pencil mark is level with the top of the collet and the pipe stop resistance is felt. Pull on pipe to check it is secure and correctly fitted.
5. To break the joint, isolate the water supply using the integral valves incorporated in the hoses, push pipe firmly into fitting, hold collet down and gently remove pipe. If the system has been filled with water care should be taken to isolate pump and towels used to absorb spilled water.

If you have any concern either about using push-fit fittings or should the joint leak on final test, isolate the water supplies and contact Aqualisa customer helpline on 01959 560010.

Cont...

Pump connections (General)

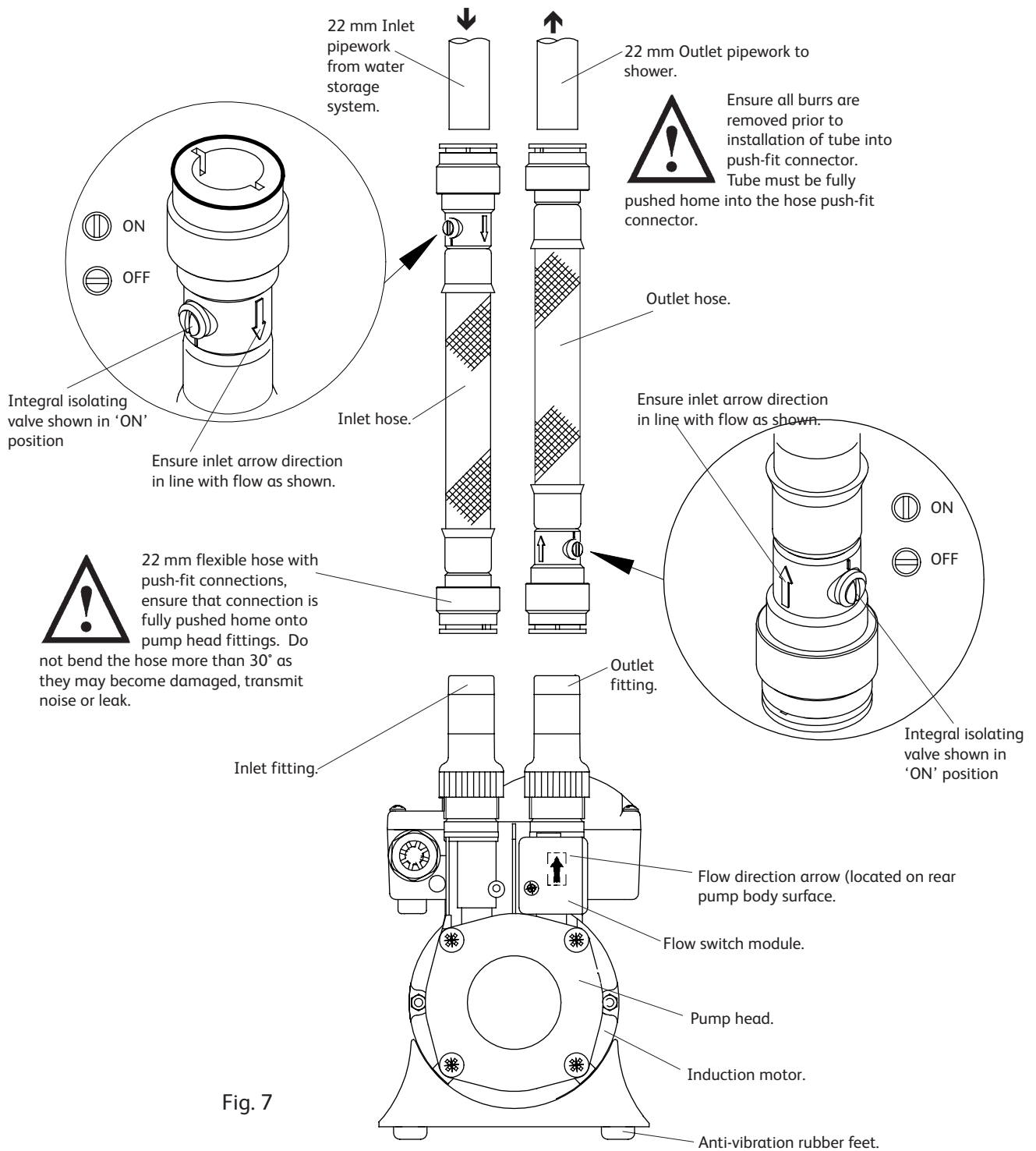

Fig. 7

The pump should not be screwed down, ensure anti-vibration feet and flexible hoses are used.



Do not operate the pump with any of the flexible hose isolation valves in the 'OFF' position. Damage will occur!

STEP 4 ELECTRICAL INSTALLATION



- The electrical installation must be carried out in accordance with the current national electrical regulations and installed by a competent person.
- In the interests of electrical safety a 30 mA. residual current device (R.C.D.) should be installed in the supply circuit. This may be part of a consumer unit or a separate unit.
- Before starting work on the electrical installation ensure the power supply is isolated.
- This appliance must be earthed.
- The motor and wiring must not be exposed to water.
- Do not allow the supply cord to contact hot surfaces, including the motor shell, pump body or pipework. The cord should be safely routed and secured by cable clips.

The motor fitted to this pump is suitable for a 230/1/50Hz supply. It is thermally protected by an integral auto resetting thermotrip for your safety and rated for the duty listed in the technical specification section.

Electrical connection

The motor is provided with a factory fitted supply cord. This must be permanently connected to the fixed wiring of the mains supply. Means for disconnection must be incorporated in the fixed wiring in accordance with the wiring rules.

A suitable method of connection would be via a double pole switched, fused connection unit complying with BS 1363-4, protected with a fuse (see fuse section).

The connection unit should be mounted in an easily accessible position and should be labelled if confusion is possible, to allow easy identification of the pump isolating switch.

Earthing

This appliance must be earthed via the supply cord, which must be correctly connected to the earth point located in the terminal box.

Copper or metallic pipework must have supplementary earth bonding where the continuity has been broken by flexible hoses or plastic components. Adjacent suction and delivery pipes should be fitted with earthing clamps to BS 951 and connected with earthing wire size 4 mm² (see Fig. 8).

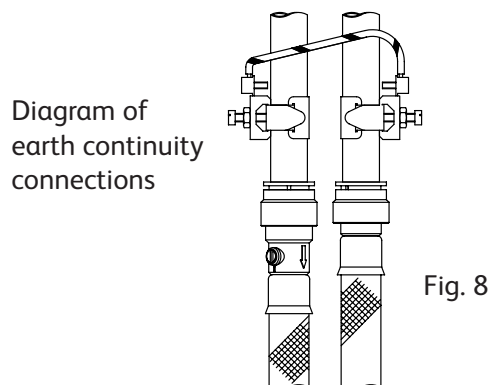

Certain installations may require additional earthing arrangements such as equipotential bonding. Reference should be made to the relevant regulations concerning this subject to ensure compliance.

Wiring of connection unit



WARNING: This appliance must be earthed.

The wires in the mains lead (supply cord) are coloured in accordance with the following code:

Green and Yellow: Earth

Blue: Neutral

Brown: Live

As the colours of the wires in the mains lead of this appliance may not correspond with the coloured markings identifying the terminals in your connection unit proceed as follows:

The wire which is coloured green and yellow must be connected to the terminal in the connection unit which is marked with the letter E or by the earth symbol: or coloured green or green and yellow.

The wire which is coloured blue must be connected to the terminal which is marked with the letter N or coloured black.

The wire which is coloured brown must be connected to the terminal which is marked with the letter L or coloured red.

Wiring diagram (schematic)



The supply cord and internal wiring within the terminal box are routed and secured to ensure compliance with the electrical standard EN60335-1. It is essential that any disturbance of this internal wiring is avoided and the factory routing and securing of all internal wiring is always maintained.

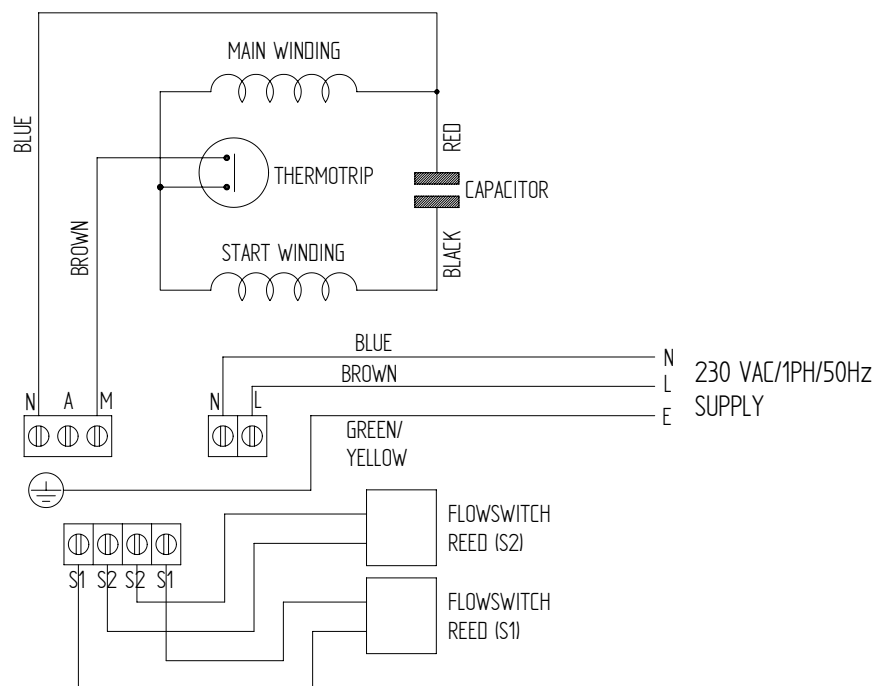

Mach 120 Twin

Fig. 9

Fuses

The following fuse size should be used with the appropriate pump.

Model	Fuse size (Amps)
Mach 120	5

Supply cord replacement



The supply cord and internal wiring within the terminal box are routed and secured to ensure compliance with the electrical standard EN60335-1. It is essential that prior to any disturbance of this internal wiring, all cable routing and securing details are carefully noted to ensure re-assembly to the same factory pattern is always maintained.

If the supply cord is to be changed or is damaged, it must be replaced with a special cord assembly available from Aqualisa or one of their approved repairers.

On disassembly note the cord retention and routing system. Reassemble to the same pattern. For information on cable connection consult the wiring diagram and cable gland fitting instructions.

Cable gland fitting instructions

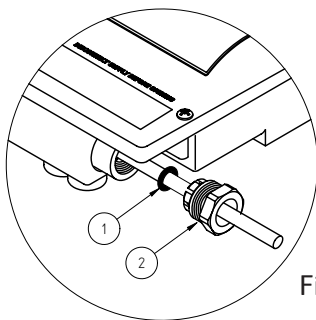

Fig. 10

To enable correct assembly of the cable gland the 'O'-ring (1) must be placed over the cable before the clamping insert (2) can be tightened.

Note: Cable diameter range:- 6.5 mm to 9.5 mm.

Supply cord extension

The pumps are fitted with a supply cord to the following specification:-

All models HO5VV-F3 G 0.75 mm² - 6 Amp rated cable.

If the supply cord is to be extended, a cord of the same specification should be used. Any connections or junction boxes used should be specifically suited for the application and installed in accordance with the manufacturers instructions.

STEP 5 COMMISSIONING

WARNINGS:



- The motor casing can become very hot under normal operating conditions, care should be taken to ensure it cannot be touched during operation.
- Do not run pump without guards and terminal box lid correctly fitted.
- The pump chamber must be full of water at all times. Seal damage will result if the pump runs dry.
- Do not operate the pump with any of the flexible hose isolation valves in the 'OFF' position. Damage will occur!



1. System flushing
This pump incorporates push-fit connectors and plastic components that must not come into contact with solder flux, acid-based descalents or aggressive cleaning agents. The pipework system should be flushed out prior to the pump being connected to ensure any contaminants/chemical residues and foreign bodies are removed from elsewhere in the system.



2. Water supply

Always ensure that water storage capacity is adequate to meet the demand. Ensure the pump chamber is full of water before starting the pump. Failure to do this could result in seal damage. To ensure dry running does not occur the pump must be primed as described in priming section. **Do not run pump dry.**

3. Priming

The pump must be primed (filled with water) before starting. Turn on water supply, prime and vent the pump by opening the outlet valve to allow pump to fill and vent. The pump is a twin pump and both pump chambers must be independently primed.

4. Pre-start check

Always ensure the pump is in a positive head position with flooded suction. A gravity flow of approx. 1 litre/min from the highest outlet is required to operate the integral flow switch.

5. Starting

- a) Switch on power and open terminal fitting. Pump should start and stop upon demand.
- b) Open and close all outlets in turn associated with the pump, allowing water to flow from each outlet until all air is purged. As each outlet is opened and closed, the pump will start and stop respectively.
- c) Any tap or control valve within the system when opened and closed will now turn the pump on/off. Check system for leaks, if clear the system is now operating correctly.

For further technical support

Phone the Aqualisa customer helpline on 01959 560010. Our staff are trained to help and advise you over the phone or arrange for a service engineer to call.

Cont....

MAINTENANCE

WARNINGS:



- Care should be taken to protect pump from frost, particularly when located in loft position.
- Pump location:
If possible site the pump in a location where in the unlikely event of a water leak, any spillage is contained or routed to avoid electrics or areas sensitive to water damage.



1. No routine maintenance is required, but provision should be made for easy access to the pump to allow repairs due to normal wear and tear.
2. Disconnect electrical supply before working on pump.
3. Turn off water supplies to the pump and release pressure by opening water outlets before attempting maintenance.
4. When the installation is fitted with inline strainers (not supplied with kit), these may require periodical cleaning. The frequency of this operation is dependent upon installation conditions.
The strainer should be located in the inlet pipework to the pump.
 - a) Isolate pump electrically.
 - b) Release all system pressure.
 - c) Isolate water supply.
 - d) Consult strainer manufacturers instructions for cleaning the unit.
 - e) After maintenance is completed, refer to commissioning section for instructions on re-starting pump.
5. As water is heated scale deposits are released in areas of hard water, scale can cause the mechanical seal to stick if left without use for long periods. We recommend the pump is run for at least 5 minutes every four weeks to “exercise” all working parts. Run on cool water. See technical specification for note on water temperature. This particularly applies to applications subject to infrequent use, for example guest bathrooms.

Cleaners, Disinfectants and Descalents



On installations where chemical disinfectants or descalents are periodically used, the compatibility of the chemical solution regarding the pump must be considered. Acid based descalents and aggressive cleaning agents must not come into contact with the pump. The pump must be removed from the system prior to the use of these products. The system should be flushed to remove all chemicals before the pump is re-connected.
If in any doubt as to the suitability of the chemical solutions then please contact the Aqualisa customer helpline on 01959 560010.

Cont...

TROUBLE SHOOTING GUIDE

Symptoms	Probable cause	Recommended action
Pump will not start.	<p>Electrical supply.</p> <p>Faulty reed switch/PCB.</p> <p>Insufficient gravity flow.</p> <p>Motor thermotrip activated.</p> <p>Water supply.</p> <p>Strainers blocked.</p>	<p>Check wiring connections. Check all switches are 'on'. Check fuse (see fuse section). Check circuit breaker is set.</p> <p>Refer to circuit test as detailed in Fig. 11.</p> <p>Check that the gravity flow of water is available to the fittings of approx. 0.8 l/min.</p> <p>Wait for thermotrip to auto-reset and check that duty point and run time is within specification (see technical specification).</p> <p>If no... check water in the supply cistern and all stopcocks are open.</p> <p>Remove and clean inlet strainers (see maintenance section).</p>
No hot water.	<p>Air locked water feed.</p> <p>Boiler is switched off.</p> <p>All hot water has been used.</p> <p>Faulty thermostatic mixer valve.</p>	<p>Vent hot water pump of air. Check cold feed to hot water cylinder. Check water level in cold water cistern and that all stopcocks are open.</p> <p>Check boiler is switched 'on'. Check cylinder thermostat. Check immersion heater. Check cylinder contains hot water.</p> <p>Check cistern volume is adequate.</p> <p>Consult valve instructions.</p>
Pump starts when outlets are off.	Leak in system.	Check tap washers and pipe joints.
Pump runs on when all terminal outlets are closed.	<p>Leak in system.</p> <p>Faulty reed switch or P.C.B.</p> <p>Flow switch reed damage.</p>	<p>Check tap washers and pipe joints.</p> <p>If pump continues to run, this indicates a closed circuit in either the flow switch reed or P.C.B. in the terminal box, these should be checked electrically.</p> <p>Test flow switch circuit (Fig. 11).</p>
Reduced flow/performance.	<p>Blocked inlet strainers.</p> <p>Blocked shower head spray plate.</p> <p>Blocked pipework or pump.</p>	<p>Clean inlet strainers (see maintenance section).</p> <p>Clean in accordance with manufacturers instructions.</p> <p>Isolate pump electrically and hydraulically, locate blockage and remove.</p>

Flow switch circuit test

1. First confirm visually that the flow switch modules have not been dislodged during handling or installation. The modules must be fully located to the pump body with the fixing screw as shown.
2. To carry out the following test you will need to obtain a magnet, a typical fridge magnet is suitable.
3. Ensure the power supply is switched on.
4. Position the magnet directly in front of the reed switch module as shown. If pump does not start, then slowly move the magnet up and down to a position that exceeds the extent of the reed switch module. The pump should instantaneously start at some point during this extent of movement. If this does not happen, this indicates a possible fault with the reed switch or the P.C.B which is located within the terminal box. These should be checked electrically. Contact the Aqualisa customer helpline on 01959 560010 for further assistance.

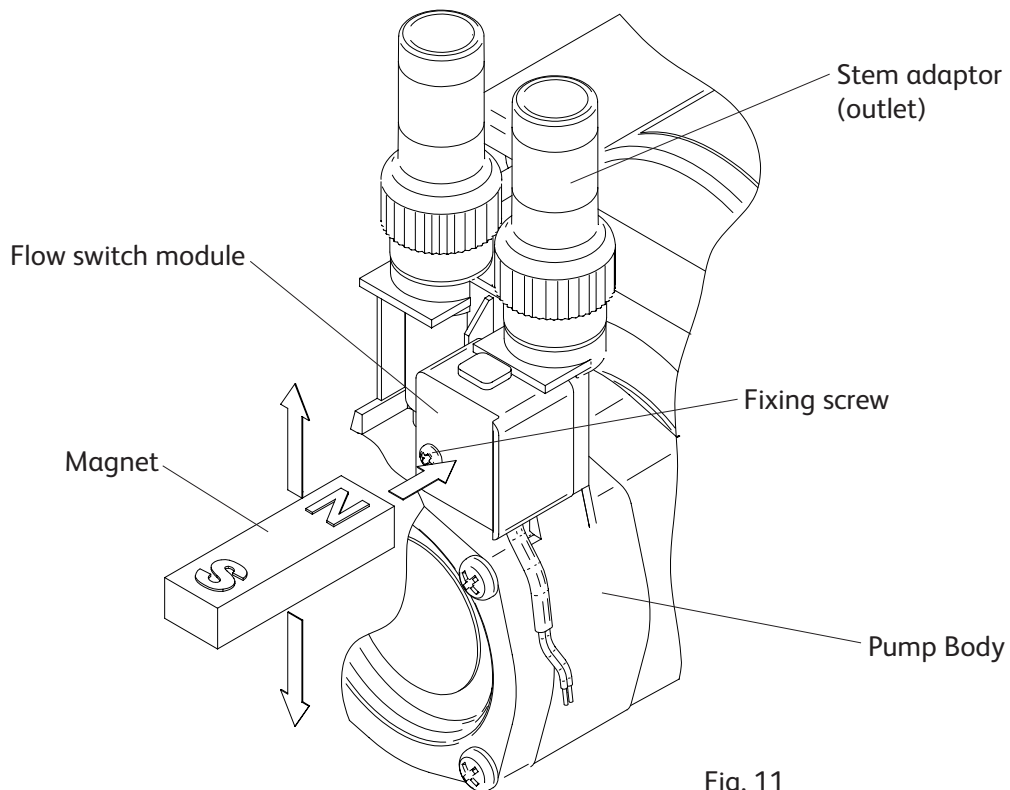

Fig. 11

TECHNICAL SPECIFICATION

Model		Mach120
Electrical	Power supply Volts/phase frequency	230/1/50
	Enclosure	IP22
	Type of motor	Induction
	Power consumption	430 Watts
	Full load current	1.9 Amps
	Rating	Intermittent (S3) 20 mins on/40 mins off @ 15 l/min
	Max. No Starts per hour	60
Mechanical	Max inlet head	13 metres
	Max head (closed valve)	18.6 metres
	Max working pressure	370 kPa (3.7 bar)
	Max ambient temperature	40°C
	Max water temperature*	65°C
	Min water temperature	4°C
Dimensions	Length	306 mm
	Width	126 mm
	Height (excluding flexible hoses)	223 mm
	Weight packed	5.6 Kg

Aqualisa reserve the right to amend the specification in line with its policy of continuous development of its products.

*Note: In normal circumstances the temperature of stored water should never exceed 65°C. A stored water temperature of 60°C is considered sufficient to meet all normal requirements and will minimise deposition of scale in hard water areas.

NOISE

The equivalent continuous A-weighted sound pressure level at a distance of 1 metre from the pump does not exceed 70 dB(A).

GOOD PRACTICE

Always flush system prior to installing a new or serviced pump.

Always ensure both sides of the pump are primed (filled with water) before starting the pump.
DO NOT RUN PUMP DRY.

Always ensure the pump is in a positive head position with flooded suction.

Always ensure anti-vibration feet are used.

Ensure pump is sited in dry ventilated position.

Abide by the Water Supply (Water Fittings) Regulations 1999.

Ensure earth continuity between suction and delivery pipes.

Always ensure pump wiring conforms with the current national electrical regulations and is installed by a competent person.

Do not operate the pump with any of the flexible hose isolation valves in the 'OFF' position.
Damage will occur!

Do not install a non-return valve, or devices which contain non-return valves, in the suction (inlet) pipework to the pump. The pump must be free to vent to the cold water storage cistern at all times.

NOTES



DECLARATION OF CONFORMITY

98/37/EC

BS EN ISO 12100-1, BS EN ISO 12100-2, BS EN 809

73/23/EEC

BS EN 60335-1, BS EN 60335-2-41, EN 50366

89/336/EEC

BS EN 55014-1, BS EN 55014-2, BS EN 55022, BS EN 61000-3-2, BS EN 61000-3-3,
BS EN 61000-4-2, BS EN 61000-4-3, BS EN 61000-4-4, BS EN 61000-4-5, BS EN 61000-4-6,
BS EN 61000-4-11

IT IS HEREBY CERTIFIED THAT THE STUART ELECTRIC MOTOR DRIVEN PUMP AS
SERIAL NUMBER BELOW, COMPLIES WITH THE ESSENTIAL REQUIREMENTS OF THE
ABOVE E.E.C. DIRECTIVES.



RESPONSIBLE PERSON
AND MANUFACTURER

STUART TURNER LIMITED
HENLEY-ON-THAMES, OXFORDSHIRE
RG9 2AD ENGLAND.

Signed Quality Manager

Stuart Turner are an approved company to BS EN ISO 9001:2000

AQUALISA

Aqualisa Products Ltd
The Flyers Way,
Westerham, Kent TN16 1DE

Sales enquiries: 01959 560010
Republic of Ireland 01-864-3363

Customer helpline: 01959 560010
Republic of Ireland 01-844-3212

Brochure Hotline: 0800 652 3669
Website: www.aqualisa.co.uk
Email: enquiries@aqualisa.co.uk

Please note that calls may be recorded for training and quality purposes